

## Možnosti montáže

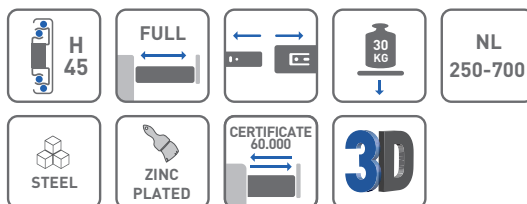

## Parametry



## Balení



## Další informace

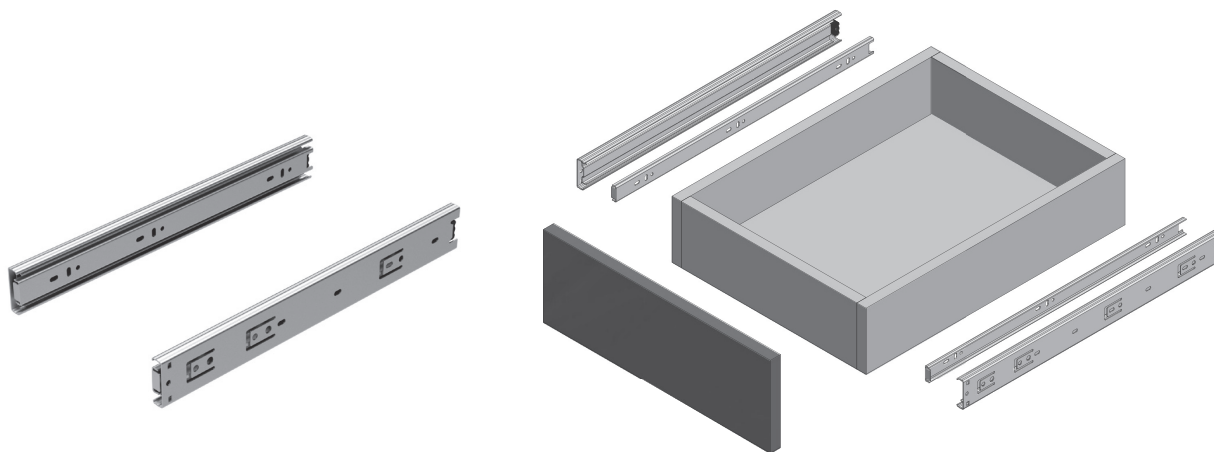

NL mm		AV mm
250		5
300		-
350		-
400		-
450		-
500		-
550		-
600		-
650		-
700		-

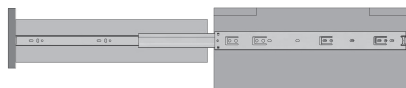

NL = Nominální délka výsuvu

AV = Ztráta plnovýsuvu při otevření

# Plánování

## Šířka zásuvky

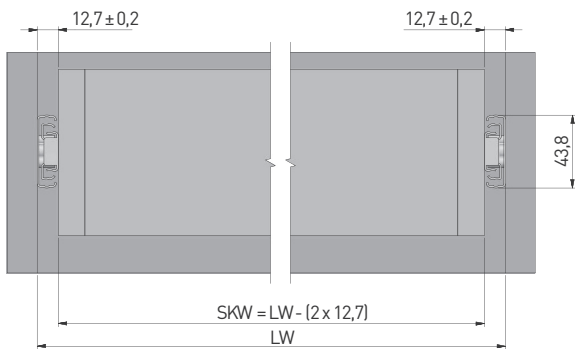

LW = Vnitřní šířka skříňky      SKW = Šířka zásuvky (šuplíku)

## Standardní zásuvka (šuplík)

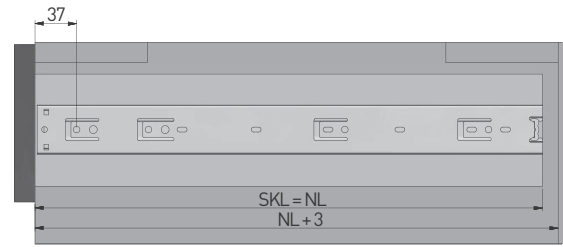

## Zásuvka s čílkem mezi boky skříňky

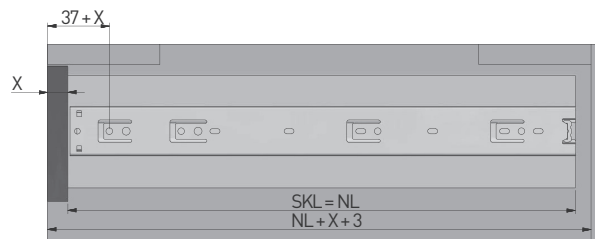

X = Tloušťka čílka

SKL = Hloubka zásuvky (šuplíku)

NL = Nominální délka výsuvu

## Rozteče montážních otvorů u jednotlivých délek

